



ASEAN
NCAP

www.aseancap.org

Safer Cars for ASEAN Region

INTRODUCTION OF ASEAN NCAP



FIA Foundation
for the Automobile and Society



GLOBAL NCAP



AUTOMOBILE ASSOCIATION
OF SINGAPORE



What is NCAP?

- NCAP stands for “**New Car Assessment Programme**”
- NCAP’s role is to provide consumer a **realistic** and **independent** assessment on the **safety performance** of vehicles **recently launched** in the markets.
- NCAP Family
 - IIHS
 - 5-Star Safety Ratings (NHTSA)
 - JNCAP
 - ANCAP
 - Euro NCAP
 - KNCAP
 - CNCAP
 - Latin NCAP
 - ASEAN NCAP



Difference between NCAP and Regulation

Regulation	NCAP
<ul style="list-style-type: none"> Mandatory requirement 	<ul style="list-style-type: none"> Consumer information
<ul style="list-style-type: none"> Minimum safety level for all vehicles on the road 	<ul style="list-style-type: none"> Not all the models and versions sold in the market are assessed
	<ul style="list-style-type: none"> Always need to distinguish vehicles one from another in terms of safety performances, mainly on 2 aspects: crashworthiness and active safety <ul style="list-style-type: none"> ➤ Crashworthiness = how well the car protects its occupant in a crash ➤ Active safety = how the car avoids/mitigates the crash from occurring
	<ul style="list-style-type: none"> Requirement higher than regulation, for example: frontal impact test speed 56 km/h vs. 64 km/h

Background of ASEAN NCAP: 2007

- Inception of Malaysian Institute of Road Safety Research (MIROS) through the Road Safety Plan 2006–2010
- The idea to have an automobile safety rating with interim name Malaysian NCAP or MyNCAP.
- Inception of a unit dedicated to realize MyNCAP: Crash Safety Engineering Unit (CRASE).

Background of ASEAN NCAP: 2009

- Formation of soft landing program – Malaysian Vehicle Assessment Programme (MyVAP).
- Non-destructive assessment of vehicle—use of secondary data from the OEMs to assess the safety level of vehicles.
- Focus: Malaysian manufacturers.
- Why soft landing?
 - As introduction to OEMs of the upcoming NCAP in Malaysian market.

Background of ASEAN NCAP: 2010

- Series of crash tests performed as a start-up to MyNCAP.
 - To increase our capacity and technical capability on performing full scale crash test.
- 2010: Motorcycle crash test.
 - Gravity propelled
- 2010: First passenger car crash test.
 - Car vs. Trailer (RUPD assessment)

Background of ASEAN NCAP: 2011

- 2011: Car-to-car outdoor crash test.
 - Aged vs. new
- 2011: Motorcycle Anthropomorphic Test Device (MATD) crash test.
 - Assessment on car airbag retrofitted into motorcycle
- June 2011: Proposal to Global NCAP during the NCAP Meeting in conjunction with 22nd Enhanced Safety of Vehicle (ESC) Conference in Washington, USA (June 2011).

December 2011: MoU Signing between Global NCAP and MIROS in New Delhi.



Structure of ASEAN NCAP

Steering Committee

(MIROS, AAM, AAS, AAP, AAC & RAAT) + (Global NCAP, Latin NCAP & Australasian NCAP – Observer)

Technical Committee

(MIROS, MAI, TGGS, ITB, UOP, NTU, HCMUT, Latin NCAP & Australasian NCAP)

WG

Frontal Impact

WG

Side Impact

WG

Child Safety

WG

Safety Assist

Support from Related Parties



Stakeholders



Financial Support



Technical Support



Program Advisory

Global Plan for Decade of Action for Road Safety 2011-2020

The Decade was approved by the Moscow Ministerial in 2009 and UN General Assembly in 2010. It was launched by a global relay of events on 11th May. A Plan for the Decade has been prepared based on five pillars:

1. Building Management Capacity
2. Encouraging Safer User Behaviour
- 3. Building Safer Vehicles**
4. Building Safer Roads
5. Improving Post Crash Care



Each pillar includes indicative and interim targets to progress towards the Decade's overall goal which is to 'stabilize and then reduce the level of road fatalities'. This requires a 50% reduction in the forecast level of fatalities by 2020 which could avoid 5 million deaths, 50 million injuries and save \$3 trillion in social costs.



Pillar 3: Safer vehicles

Encourage universal deployment of improved vehicle safety technologies for both passive and active safety through a combination of harmonization of relevant global standards, consumer information schemes and incentives to accelerate the uptake of new technologies.

Activity 1: Encourage Member States to apply and promulgate motor vehicle safety regulations as developed by the United Nation's World Forum for the Harmonization of Vehicle Regulations (WP 29).

Activity 2: Encourage implementation of new car assessment programmes in all regions of the world in order to increase the availability of consumer information about the safety performance of motor vehicles.

Activity 3: Encourage agreement to ensure that all new motor vehicles are equipped with seat-belts and anchorages that meet regulatory requirements and pass applicable crash test standards (as minimum safety features).

Activity 4: Encourage universal deployment of crash avoidance technologies with proven effectiveness such as Electronic Stability Control and Anti-Lock Braking Systems in motorcycles.

Activity 5: Encourage the use of fiscal and other incentives for motor vehicles that provide high levels of road user protection and discourage import and export of new or used cars that have reduced safety standards.

Activity 6: Encourage application of pedestrian protection regulations and increased research into safety technologies designed to reduce risks to vulnerable road users.

Activity 7: Encourage managers of governments and private sector fleets to purchase, operate and maintain vehicles that offer advanced safety technologies and high levels of occupant protection.



#	Est. year	Countries	#	Est. year	Countries
1	1959	USA	6	1999	South Korea
2	1978	USA	7	2006	China
3	1991	Japan	8	2010	South America
4	1992	Australia & New Zealand	9	2011	Southeast Asia countries
5	1997	FRA, GER, ITA, ESP, SWE, NED, UK (EU)			

Why do we need NCAP in the region?



WE COMPARED...



Nissan March tested by ASEAN NCAP



ASEAN NCAP PHASE 1 RESULT RELEASE

Safer Cars for ASEAN Region

NISSAN March



Production of
Thailand

Variant: E MT
Year Built: 2012
Model Year: 2012
Vehicle Category: 4-door Hatchback
Engine Capacity: 1.2 Litre Petrol
Kerb Mass: 940 kg
Test Laboratory: MIROS PC3



Pre-requisite for 5-Star in ASEAN NCAP:

Electronic Stability Control – NO

Seatbelt Reminder – YES (Driver only)

This car is eligible for maximum 4-star.

In the absence of Electronic Stability Control (ESC) and Seatbelt Reminder (SBR) for front passenger, this model is only eligible for a maximum of 4-star rating.

Nissan's Thailand factory produces Nissan March for Brunei, Singapore and Thailand market that comes with driver airbag only as the lowest variant. Nissan Indonesia does not offer any airbag for lowest version in its domestic market, however, starting September 2013 driver airbag variant as the lowest version is an option for Indonesia market. Therefore, the star rating for Nissan March is only applied to variant with at least driver airbag.



- Breaking ground of MIROS crash lab in 2012.
 - Provisional CRASE Crash Centre (MIROS PC3)
- May 2012: First official ASEAN NCAP test at MIROS PC3 on Toyota Vios
 - Witnessed by HRH Prince Michael of Kent (FIA Foundation)

MIROS PC3 ASEAN's 1st Crash Lab



Toyota Vios Crash Test Video by ASEAN NCAP



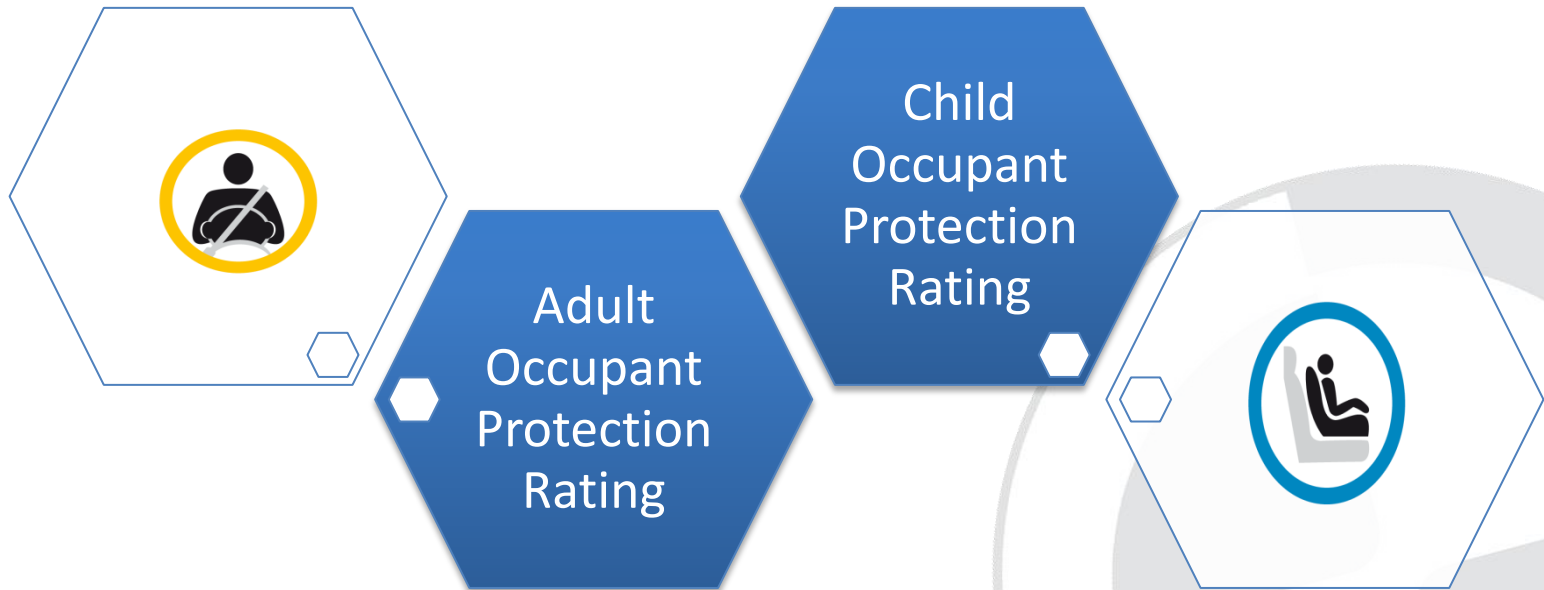

Crash Test Video



ATTENTION

**Any copying and reproduction of this material
without expression of MIROS is strictly forbidden**



AOP Rating

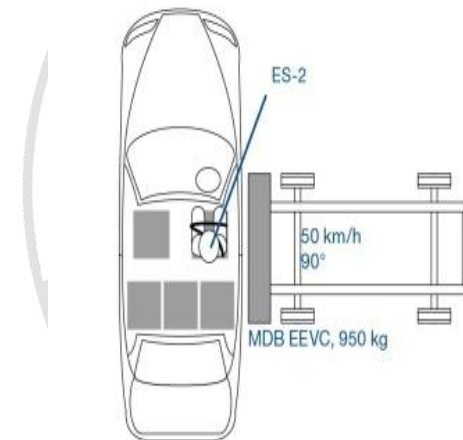
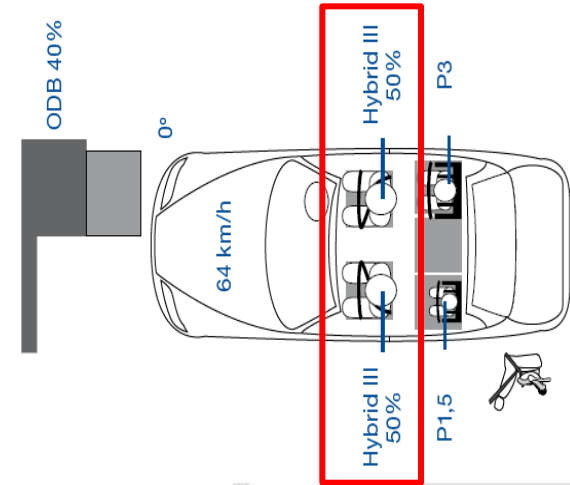
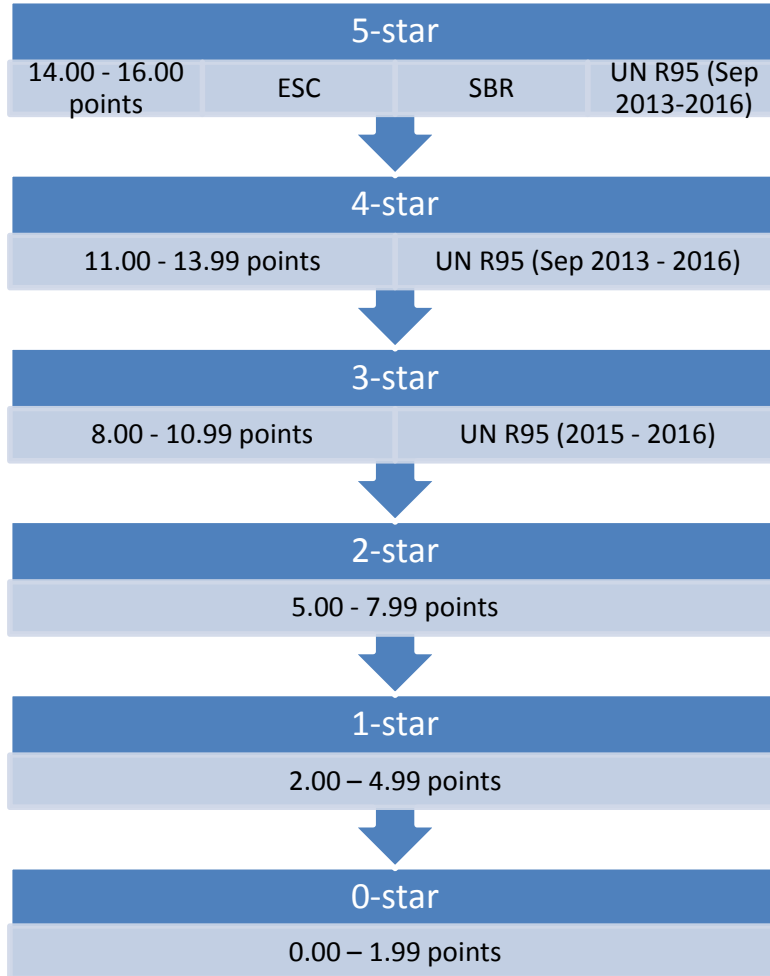

Each Body region gets the colour according to its assessment, i.e. points derived from the load minus modifier.

- 4,00 points
- 2,67 – 3,99 points
- 1,33 – 2,66 points
- 0,01 – 1,32 points
- 0,00 points

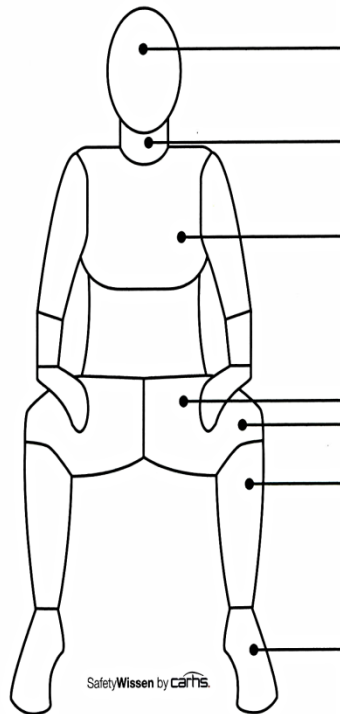

Airbag	
Modifier	Airbag Deployment Modifier for incomplete unfolding of any Airbag (-1 Point)

Head	
4 points	HIC 36 < 650; a_{rms} < 72 g
0 points	HIC 36 > 1000; a_{rms} > 88 g
Modifier	unstable airbag contact (-1 point), Steering column displacement (-1 point)

Neck	
4 points	$M_{\text{y-tension}}$ < 42 Nm Tension: < 2,7 kN @ 0 ms < 2,3 kN @ 35 ms < 1,1 kN @ 60 ms Shearing: < 1,9 kN @ 0 ms < 1,2 kN @ 25 – 30 ms < 1,1 kN @ 45 ms
	$M_{\text{y-tension}}$ > 57 Nm Tension: > 3,3 kN @ 0 ms > 2,9 kN @ 35 ms > 1,1 kN @ 60 ms Shearing: > 3,1 kN @ 0 ms > 1,5 kN @ 25 – 35 ms > 1,1 kN @ 45 ms

Chest	
4 points	Deflection < 22 mm; VC < 0,5 m/s
0 points	Deflection > 50 mm; VC > 1,0 m/s
Modifier	Deformation A-Pillar (-2 points) Compartment deformed (-1 point) Contact with steering wheel (-1 point)

Femur	
4 points	Compression force < 3,8 kN
0 points	Compression force > 9,07 kN > 7,56 kN @ 10 ms

Knee	
4 points	Displacement < 6 mm
0 points	Displacement > 15 mm
Modifier	Variable contact (-1 point) Concentrated Loading (-1 point)

Tibia	
4 points	TI < 0,4; Compression force < 2 kN
0 points	TI > 1,3; Compression force > 8 kN
Modifier	z-displacement of worst pedal (-1 point)

Foot	
4 points	x-displacement braking pedal < 100 mm
0 points	x-displacement braking pedal > 200 mm
Modifier	footwell intrusion (-1 point) blocked pedal (-1 point)

Source: SafetyWissen

AOP POINTS 14.07

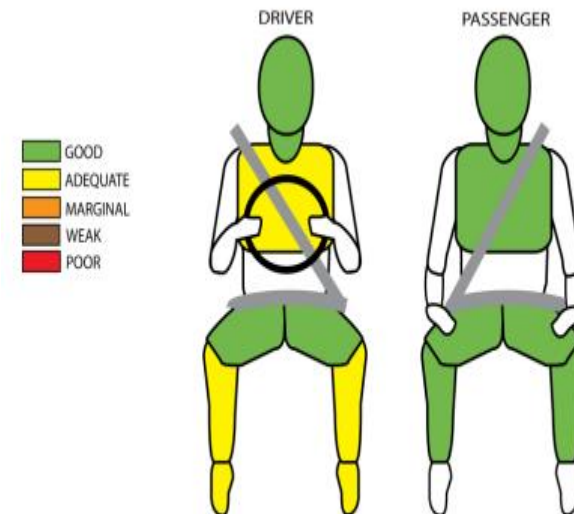

MODIFIER Footwell rupture

Steering Column Displacement



Compartment Integrity



Knee Area



Foot Area





COP Rating

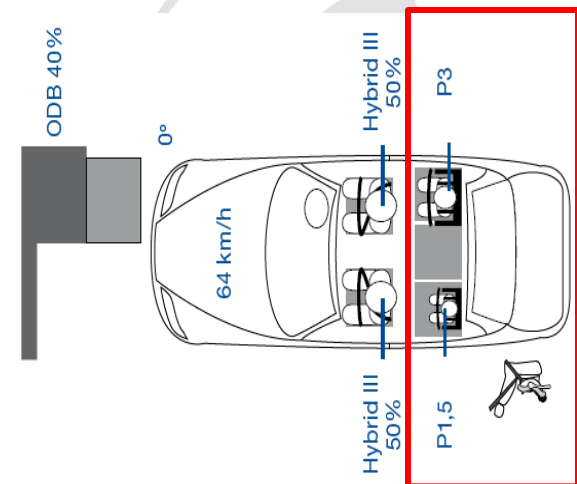
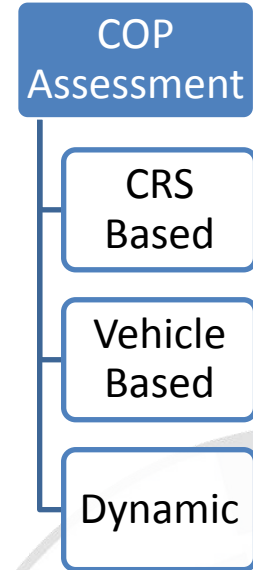
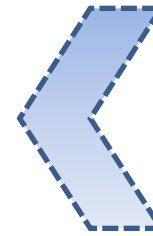
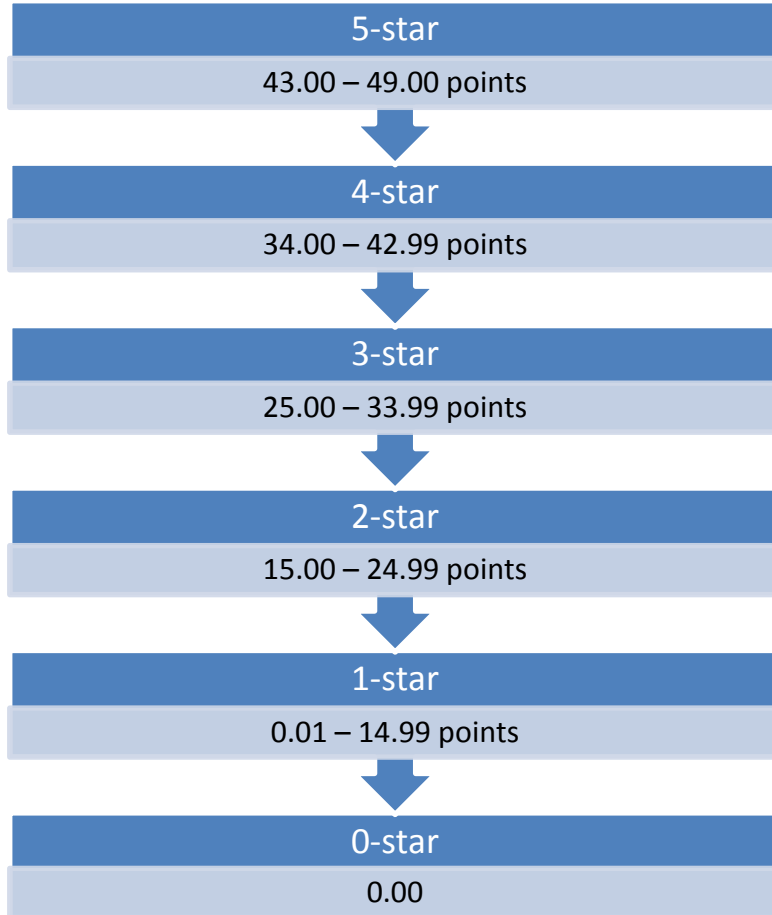

Assessment Method

Requirements	Score
<p>Dynamic Assessment</p> <p>Pre requisites - no partial or full ejection of child dummy out of CRS / CRS must not be partially or wholly unrestrained by any of the vehicle interfaces</p>	24
<p>CRS Based Assessment</p> <ul style="list-style-type: none"> •CRS marking - 8 points •CRS to Vehicle Interface - 4 points 	12
<p>Vehicle Based Assessment</p> <ul style="list-style-type: none"> •Use of CRS on the Front Seat - 5 points •Provision of three-points seat belts (Passengers) - 1 points •Gabarit assessment (outboard Rear) - 1 points •Gabarit assessment (other passenger seats) - 1 points •ISOFIX - 3 points •Integrated CRS - 2 points 	13
Total	49

- 2 Types of gabarit assessment
 - Normal



- Gabarit for larger ISOFIX



Reminder For Front Seat



Passenger Airbag On/Off



- The test is primarily for public consumption, i.e. for consumers to consider the quality of safety protection offered by the car model based on NCAP assessment.
- ASEAN NCAP has dual rating assessment:
 - **Adult Occupant Protection (AOP)**
 - **Child Occupant Protection (COP)**

First Version of Result Plate



Old Plate

Used in
Pilot Phases
1 & 2

Latest Version of Result Plate



New Plate

Beginning from Phase III in 2014, ASEAN NCAP revised the rating plate by including the star rating for COP, fitment status of Safety Assist Technologies (ESC and SBR) and UN R95 result (Figure 3).

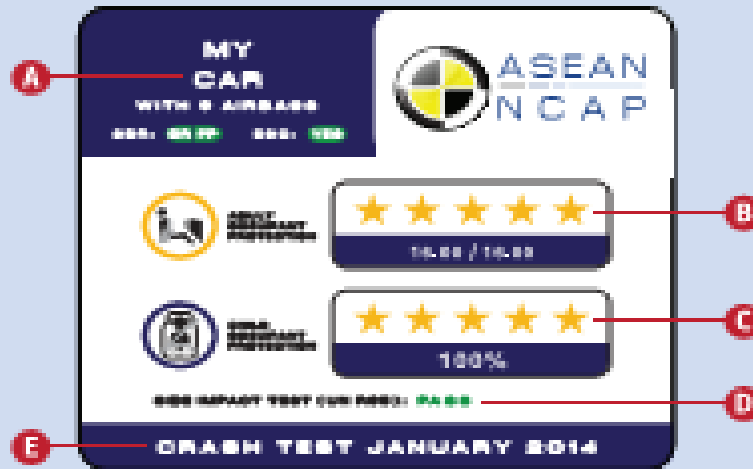

Figure 3 - Newly revised ASEAN NCAP rating plate that includes fitment for Safety Assist Technologies and UN R95 result

- A Make & Model**
Fitment status: Electronic Stability Control (ESC) & Seatbelt Reminder (SBR) - DR for driver, FP for front passenger.
Green: Available **Red: Not available**
- B Star rating for AOP**
- C Star rating for COP**
- D Side impact test result**
- E Month & year crash test conducted**

Media & News



&



Examples of Online News from Malaysia

4/7/2016 TopGear Malaysia - ASEAN NCAP crash tested the latest Hilux



Home > News > ASEAN NCAP crash tested the latest Hilux

ASEAN NCAP crash tested the latest Hilux

Published on Monday, 21 September 2015 14:04

ASEAN NCAP has released the test crash result of the latest Toyota Hilux, the newest model of Asian number one vehicle.



It is then not a surprise that the new Hilux scored a full 5-star rating for ADP and Astar GCP.

During the Asian Automotive Safety Forum in Bandung (taking place) right now from 20 - 22 September at Institut Teknologi Bandung, ASEAN NCAP has released a more crash test results - this time around targeting cars for the Indonesian market.



According to Khair Anwar, Assistant Secretary-General for ASEAN NCAP, the Hilux was tested before by Global NCAP and the previous result was a 5-star rating. However, it was improved on the car's body structure and added an airbag, making it a safer car than before.



http://www.topgear.com/my/index.php?option=com_content&view=article&id=2756:asean-ncap-crash-tested-the-latest-hilux&catid=34:news&Itemid=... 1/3

paultan.org
Malaysia's #1 source for automotive news

Make the RIGHT choice at



MALAYSIA'S #1 CAR BUYER'S GUIDE

HOME MALAYSIAN NEWS CAR REVIEWS FEATURES SPYSHOTS PRICELIST CARS FOR SALE BIKES VIDEOS TECH WATCHES BAHASA TOOLS

SEARCH OUR STORIES

Home > Local News > Honda BR-V gets 5-star ASEAN NCAP rating with ESC

Honda BR-V gets 5-star ASEAN NCAP rating with ESC

In Cars, Honda, Local News / By Gerard Lye / 1 April 2016 9:32 am / 3 comments

[Like](#) [Share](#) 258 people like this.





ASEAN NCAP
Safer Cars for ASEAN Region

ACT001 Honda BR-V
8 February 2016

5.0 AOP
14.79 / 16.11

5.0 COP
72%

oto.my
SELL YOUR CAR FAST

SELL YOUR CAR

Relevant Listings	Make	Latest	Price
RECORDED	2010 Honda Civic Type R 2.0 (M)	Honda Civic-R 2.0 FD2 - UNREG 2010 ...	RM 150,000 Kuala Lumpur
RECORDED	2008 Honda Elysion 2.4	Honda Elysion 2.4 - UNREG 2008 - LE...	RM 151,000 Kuala Lumpur
USED	2005 Honda CR-V 2.0 (A) IVTEC NEW ...	***Honda CR-V 2.0 (A) IVTEC NEW FAC...	RM 43,800 Kuala Lumpur
USED	2006 Honda Stream 2.0 i-VTEC 7 L Se...		

If you're holding out for the arrival of the Honda BR-V, here's an important update about the crossover in regards to its safety. Today, the ASEAN NCAP has released its testing results for the BR-V, and it's good news for prospective buyers.

That's right, the crossover, which comes in seven- and five-seater configurations (depending on markets), managed to obtain a five-star rating, scoring 14.79 points out of a possible 16 in the Adult Occupant Protection (AOP). Meanwhile, the BR-V managed a 72% compliance in Child Occupant Protection (COP).

However, due to the ASEAN NCAP five-star requirements, where Electronic Stability Control (ESC) is required to receive said rating, the crossover will receive two ratings depending on the variant specified.

Example of News in Malaysia Print Media

No. 6402 FP 2644/12/012 (03119) www.thesundaily.my 30 SEN FOR DELIVERY VIA YOUR VENDOR. CALL 03-77852731



TELLING IT AS IT IS
the Sun
ON THURSDAY
305,000 COPIES DAILY

INSIDE

- ▶ Don't conspire to bring down country: Najib page 02
- ▶ Next Gen: John meets jazz page 23
- ▶ 1MDB tells Pua: Show us the evidence page 06

PRaising the Prophet
Muslims taking part in the 'Maulid Nabi' procession, marching from Duta North towards the 'Garis Rukun' (Lumpur) yesterday to commemorate Prophet Muhammad's birthday in Mexico to Maulid Nabi and to mark the first day of the Islamic and the 'golden year' known as 'Uluhi, The Pulse of Nations Transformation.'

Vanuatu's 'corrupt' acting president pardons himself

SYDNEY: Vanuatu's President Baldwin Lonsdale said he was "deeply sorry" and vowed to clean up the government after the country's acting leader pardoned himself and 13 other parliamentarians on bribery convictions.
Parliamentary speaker Marcelino Nijpe reportedly issued the pardon as acting president on Sunday, while Lonsdale was overseas in Samoa, after the 14 were convicted for bribery by the Supreme Court Friday.
Nijpe said he had done it out of the national interest rather than for personal benefit, the Australian Broadcasting Corporation reported.
"I decided to make such orders to maintain the peace, unity and stability of this country," he said.
Lonsdale, who was reportedly visibly shaken when he addressed the nation after he returned on Sunday, said "no one is above the law" and called Nijpe's actions unlawful.
"There exists a backyard which needs to be cleaned," Lonsdale said.
"I am considering my options as to how to clean up the mess by consulting with the state law officers."
"Vanuatu's credibility has been tarnished throughout the world since the incident - AFP



SAFER cars
All new vehicles to have STANDARD safety assist technologies by 2017

BY SHAHRIM TAMRIN
news@thesundaily.com

PETALING JAYA: A host of electronic devices will be among the standard safety features to be found in all new cars in Malaysia soon.

They include anti-lock braking system (ABS), electronic stability control (ESC), blind spot technology, automated emergency braking (AEB), lane departure and forward collision warning systems.

Also to be found in all new cars is that sensor which gives out the irritating sound as a seat belt reminder for driver, front and rear passengers.

These are part of the safety assist technologies (SAT) for all new passenger cars in Southeast Asia by 2017.



INTERPACIFIC SECURITIES SDN. BHD.
A Participating Organisation of Bursa Malaysia Securities Berhad
A Trading Participant of Bursa Malaysia Derivatives Berhad

mobile trading anywhere anytime

www.paonline.com.my

Available on Google play and App Store

Berjaya Times Square Tel: 03-2177 8888
Danau Desa Tel: 03-7994 7796
Seri Petaling Tel: 03-9056 2022
Johor Bahru Tel: 07-223 1211
Penang Tel: 04-269 0880

04 | NEWS WITHOUT BORDERS

Local carmaker to get show-cause letter

> Asean NCAP probing alleged removal of child safety protection system in one of its models

BY SHAHRIM TAMRIN
news@thesundaily.com

PETALING JAYA: The safety rating awarded to a local carmaker by Asean NCAP (New Car Assessment Program) is being scrutinised after it allegedly removed a child safety protection system in one of its models early this year.

It is reliably learnt that Asean NCAP has conducted an investigation and may propose a review whether to suspend the five star safety rating awarded to the model or to reset the five star variant. Industry sources told *theStar* that the regional vehicle safety watchdog is furious with the company after receiving complaints from car buyers about the alleged non-availability of top-tether in the new generation model offered to the market lately.

"If it is true, this is a serious violation of safety and car buyer rights as well as undermining the protection for child on board," said the source.

It is also learnt that Asean NCAP will deliver a show-cause letter to the company this week and the safety body may undertake a thorough audit exercise for its three other models that have also been awarded safety star-rating under the programme.

The model in question received five stars for the child occupant protection (COP) category due to the presence of top-tether and was awarded 3-star rating based on its safety specifications for adult occupant protection (AOP) which include seat-belt reminder (for driver only) and dual airbags.

The model in question received five stars for the child occupant protection (COP) category due to the presence of top-tether and was awarded 3-star rating based on its safety specifications for adult occupant protection (AOP) which include seat-belt reminder (for driver only) and dual airbags.

Single star rating to override dual rating system

FROM FRONT PAGE

This was outlined in the Asean NCAP (New Car Assessment Program) 2007-2009 road map presented to the NCAP and participants of the International Conference on Southeast Asia's Decade of Action for Road Safety: Safe Vehicles, Indonesia recently.

Asean NCAP secretary-general Khalid Awani Abu Ezzaid said SAT will contribute to 25% of the overall safety rating for new vehicles in the next 14 months.

The new road map towards 2020 also introduces a single star rating system and eliminates the dual rating system which had caused confusion for consumers due to clever marketing ploys by car manufacturers.

We found that the dual rating system has been manipulated by some manufacturers in their advertisements," Khalid Awani told *theStar*.

For example, a car model which received a 3-star safety rating was marketed as a 5-star, which was actually awarded for a different part of the same model, he explained.

To eliminate the confusion, he said, only the lowest variant of a particular car model from within the region will undergo crash tests from now.

"It will be 20% for adult occupant protection (AOP) and 20% for child occupant protection (COP) to ensure a vehicle receives the highest star award and also provide the best protection for the child inside a car," he said.

Asean NCAP has been recognised in changing the landscape of automotive safety in the region by focusing on passive safety.

Khalid said that the new road map is a natural progression of the programme which was introduced three years ago.

Asked why the regional automobile safety body outlines NAT as a standard feature in a passenger car, he replied, "Crash avoidance is our next objective, which reflects our effort to put pressure on the car manufacturers to install more safety features and produce safer cars."

Selangor wants PKNS, KPS to explain toll hikes

BY TIMOTHY AGAHARAM AND SONG ROON MUN
news@thesundaily.com

PETALING JAYA: The Selangor State Development Corporation (PKNS) and Kumpulan Perancang Selangor (KPS) will be headed up to explain the toll hikes on selected highways.

Selangor Menteri Besar Mohamed Amin Ali said on Twitter yesterday that he will be calling the two state-owned companies, which are minority stakeholders in the Kemas and Lebuhraya Damansara-Puchong (LDP) highways, to brief the state Economic Action Council (MECS) today on the toll hikes.

"I have asked PKNS and KPS, the state government's policy is to clearly reject any toll hike that will burden the people," he said.

The state government owns 30% of the Kemas highway through PKNS and 20% in Spirit and the LDP through Kumpulan Perancang.

It was reported that toll rates at major highways in the Klang Valley are to increase between 10 sen and RM470 from today.

Meanwhile, sacked Umno member Anisa Saadudin said



Members of MAM show the police report filed at Dang Wangi police station yesterday.

the government could have used revenue from the Goods and Services Tax to compensate the highway concessionaires, instead of raising toll rates.

A non-government organisation, Pertubuhan Martabat Milin Mubtahir Malaysia (M2M), yesterday lodged a police report over the toll hike.

Its president, Abdul Razi Kulyub Abdullah, said the report lodged at the Dang Wangi police station is to urge the government and highway concessionaires to postpone the toll hikes.

"The government and toll companies should do it slowly. Don't burden the rakyat," Abdul Razi Kulyub told *theStar*.

"I represent the rakyat to defuse the situation. Don't increase the rates for now, so the people are not pressured," he added.

TEKSI M hails fare

KUALA LUMPUR: Malaysia Taxi (TEKSI M) drivers yesterday welcomed the announcement by the Land Public Transport Commission (LPTC) that fare would be reduced by year-end.

TEKSI M driver, Wong Chee Chan, 52, said the good news was long awaited. He said he hoped that it could boost public confidence towards the taxi industry.

"Many consumers avoid using TEKSI M because the fare is so expensive and I believe the new fare, which is lower than the current rate, will encourage them to use it."

Wong, who has been a TEKSI M driver for two years, said in Klang Valley, there are more than 100,000 taxis with 30 sen for every 200m.

On Monday, TEKSI M chairman Sun Sri Syed Hamid Ahrar announced that the fare rates for TEKSI M will be reduced by year-end to encourage more people to use the service - *BERNAMA*

SEE ALSO PAGE 14

MH17 families continue to cry out for justice

BY HANICAL JALIL, NARULAN HANMUDIN, AND CHODON FAHRI LEE MOO BOON
news@thesundaily.com

PETALING JAYA: Families of those on board Malaysia Airlines Flight 17 (MH17) who were not satisfied until justice is served.

Forward Suniti Singh's father, Jigar Singh, said the perpetrator who shot down the aircraft which killed all 98 passengers and crew on board still has not been identified although the results of the investigation is to be expected.

"Most of us are coming to terms with it, we expected that. It would be so easy to prove who are the perpetrator, and Russia and Ukraine are both blaming each other."

"We still do not know who are

the murderers and most families are not too happy about the report, unless we can take them to criminal court and prove that they did it," Jigar told *theStar* yesterday.

"The very best, he said, the Dutch authorities have confirmed that it was a Russian-made BUK surface-to-air missile that brought down the aircraft over the war-torn region of Donetsk in Ukraine when the plane was flying back to Kuala Lumpur from Amsterdam on July 17, 2014.

Jigar added that Ukraine must take responsibility for not closing its airspace when it is in the middle of a civil war.

Muzakir Mustafa, sister of stewardess Dora Shalika Kasian's brother, Don Shalidan Kasian, said the results of the investigation are nothing new

and the family would prefer to know who did it and what will be done by the authorities.

"They are gone, but never forgotten. I am sure justice will be done and we want to know who shot down the plane and whoever it is should be held responsible for that. We also want to know the reason. The question marks are still there unless the relevant parties take action. What action will the whole world take after the final report is released?" he asked.

He also pointed out that the contents of MH17's black box have not been released despite an assurance by the authorities that it would be done a year after the incident.

Examples of Online News from Indonesia

4/7/2016 Ford Ranger Aman untuk Orang Dewasa, Kurang Bersahabat Buat Anak - Otomotif Liputan6.com

Cari di Liputan6.com

HOME NEWS BISNIS HEALTH SHOWBIZ BLOG TEKNO LIFESTYLE GLOBAL

Home » Otomotif » Mobil

Ford Ranger Aman untuk Orang Dewasa, Kurang Bersahabat Buat Anak

By **Rita Apriana** on 19 Nov 2015 at 15:30 WIB

13 Shares / Facebook Twitter Google+ Email Copy Link



Liputan6.com, Sydney - ASEAN Global New Car Assessment Program (ASEAN NCAP) baru saja merilis hasil uji tabrak model Ford Ranger. Uji coba ini dilakukan di Crashtab di Sydney, Australia.

Dalam ribs yang ditirama Liputan6.com, Kamis (19/11/2015), Ford Ranger meraih skor 15,45 dari poin maksimal 16 dalam kategori Perlindungan Penumpang Dewasa (Adult Occupant Protection/AOP).

Namun demikian, karena Ranger tidak memiliki fitur Electronic Stability Control (ESC) dan Seatbelt Reminder (SBR) untuk penumpang depan sebagai syarat wajib ASEAN NCAP, maka lima bintang itu diturunkan satu peringkat.

Sementara itu, untuk kategori Perlindungan Penumpang Anak (Child Occupant Protection/COP), Ford Ranger memperoleh angka kepatuhan sebesar 63 persen atau setara dengan bintang tiga.

Berdasarkan hasil ini, maka dapat diketahui pula bahwa Ford Ranger lebih aman untuk orang dewasa dibanding Mitsubishi Triton (15,22 poin), Toyota Hilux (14,53 poin), dan Chevrolet Colorado (14,19 poin).

BACA JUGA

- **Ini Dasar Malaysia Uji Tabrak Mobil Murah Indonesia**
- **ASEAN NCAP Ganjar New Daihatsu Sirion Empat Bintang**
- **Ini Dasar Malaysia Uji Tabrak Mobil Murah Indonesia**

http://otomotif.liputan6.com/read/2369893/ford-ranger-aman-untuk-orang-dewasa-kurang-bersahabat-buat-anak



Kijang Innova Raih Bintang 5, Honda Brio RS Siap Meluncur, Harga Ford Fiesta Jatuh? - Otoweekly

Otoaiment **Subscribe** 9,387 **9,399**

Published on Feb 19, 2016

Up next Autoplay

- 5 Iklan Mobil yang Dilarang Tayang di TV
Otoaiment 24,361 views
- 5 Mobil Terlaris di Indonesia Sepanjang Tahun 2015
Otoaiment 35,220 views
- Mercedes-Benz Indonesia Luncurkan New V-Class, Honda BR-V Raih Bintang Lima
Otoaiment 2,515 views NEW
- All New Toyota Innova 2016 - Test Drive - OTOMOTIF TV
6,400 views
- Toyota All New Kijang Innova 2016 Review Indonesia - OtoDriver (Part 2/3) (English) Oto Driver
97,545 views
- Honda BRIO i-VTEC 2016 terbaru, mobil Pribadi yang nyaman, kecil tapi handal sight channel
1,259 views
- 6 Fakta Menarik Honda BR-V
Otoaiment

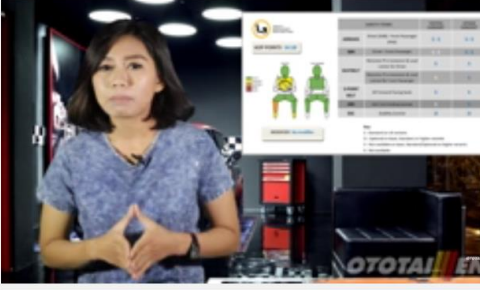

Kijang Innova Raih Bintang 5, Honda Brio RS Siap Meluncur, Harga Ford Fiesta Jatuh? - Otoweekly

Otoaiment **Subscribe** 9,387 **9,399**

Published on Feb 19, 2016

Up next Autoplay

- 5 Iklan Mobil yang Dilarang Tayang di TV
Otoaiment 24,361 views
- 5 Mobil Terlaris di Indonesia Sepanjang Tahun 2015
Otoaiment 35,220 views
- Mercedes-Benz Indonesia Luncurkan New V-Class, Honda BR-V Raih Bintang Lima
Otoaiment 2,515 views NEW
- All New Toyota Innova 2016 - Test Drive - OTOMOTIF TV
6,400 views
- Toyota All New Kijang Innova 2016 Review Indonesia - OtoDriver (Part 2/3) (English) Oto Driver
97,545 views
- Honda BRIO i-VTEC 2016 terbaru, mobil Pribadi yang nyaman, kecil tapi handal sight channel
1,259 views
- 6 Fakta Menarik Honda BR-V
Otoaiment

Examples of News in Thailand

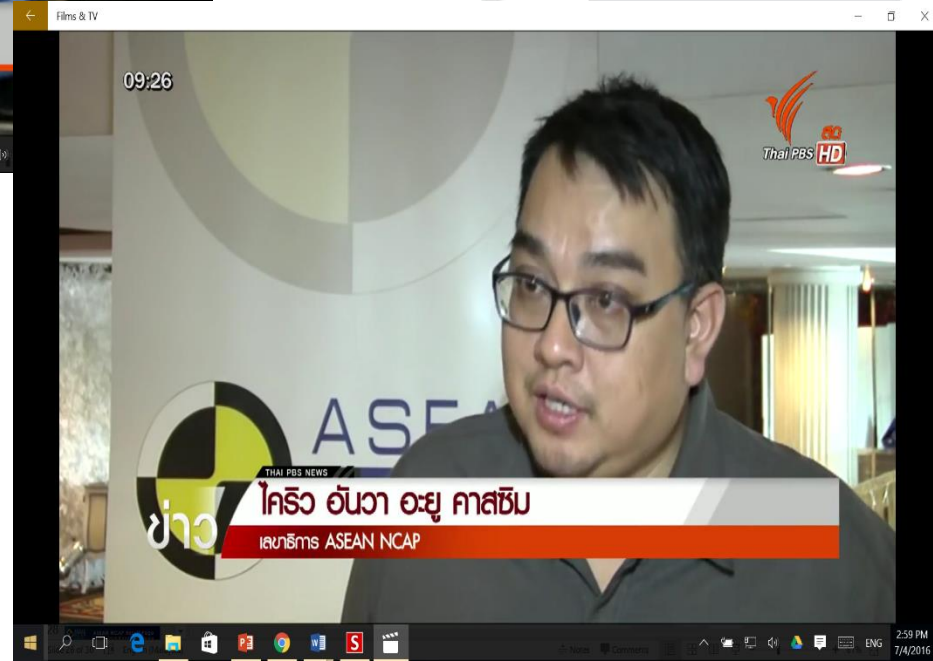
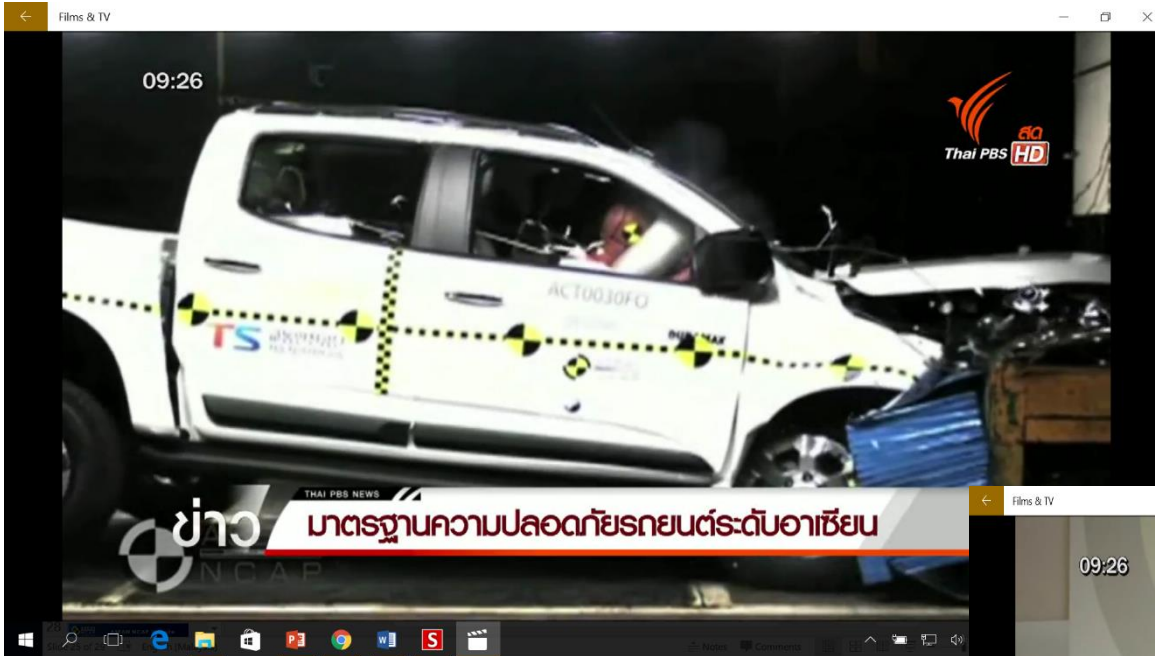

Advertisements Displaying ASEAN NCAP Rating



5 YEARS WARRANTY
Unlimited Mileage
*Terms and conditions apply.

ASEAN NCAP
Best Child Occupant Protection (Mini Car Category)
★★★★★

6 Airbags
4 Discs Brake
Electronic Stability Control (ESC) with Traction Control
21 Kilometres per litre
Low Noise, Vibration & Harshness

picanto
EVEN MORE TO LIKE

KIA
The Power to Surprise

Featuring best-in-class fuel-efficiency, comfort and now, the **Best Child Occupant Protection in Mini Car Category**, own the Picanto now from RM54,888**†

*Valid for 1.2MT model (Based on New European Driving Cycle Fuel Economy Test)
**Price valid for Perak only. Malaysia only.

MONTHLY
INSTALLMENT
AS LOW AS
**RM
250***
* Terms & conditions apply



It is amazingly affordable!

Introducing the new Proton SAGA SV, the car anyone can afford to own. At RM250* a month, definitely worth buying. It's equipped with safety features, practical, roomy and comfortable. It is driver-friendly and it suits any lifestyle. Call us today to find out how you can be a proud owner of a Proton SAGA SV. Price starting from RM33,888.* **Wow... What a bargain!**



READY TO MEET EVERY NEED

Your Alza, your way. Shape it to meet your requirements with ease.



*Static condition

SAFETY AND PERFORMANCE

Every ride is an adventure. Every journey comes with peace of mind.



**Only available with SE and Advanced Version variants.



The high performance 1.5L DVVT DOHC with EFI engine delivers excellent fuel economy, smooth pick-up and acceleration, and cleaner gas emissions with minimal vibration noise.

DVVT DOHC EFI

Dynamic Variable Valve Timing Double Overhead Camshaft Electronic Fuel Injection

BETTER POWER TO WEIGHT RATIO

Equipped with a 1.5L engine with 184kW/6000rpm (max. output) and 138Nm/4400rpm (max. torque) in a lightweight body, the Perodua Alza is engineered to deliver better performance and lower fuel consumption.

PROTON IRIZ

ASEAN NCAP Q3 2014 (September)



VARIANT 1.6 L EXECUTIVE
YEAR BUILT 2014
MODEL YEAR 2014
VEHICLE CATEGORY HATCHBACK
ENGINE CAPACITY 1.6 L PETROL
KERB MASS 1150
TEST LAB PC3

TESTED VARIANT ORIGIN	MALAYSIA	FOR	MALAYSIA
OTHER ASEAN PRODUCTION	MALAYSIA	FOR	MALAYSIA, THAILAND, INDONESIA, BRUNEI, SINGAPORE

Proton Iriz, which is set to be launched into Malaysia's market in September 2014, will be the latest product by Malaysia's car maker Proton. This hatchback scored well in the Adult Occupant Protection (AOP) with 14.07 points, which is in the 5-Star range. For Child Occupant Protection (COP), it scored 4-Star with 82% compliance. ISOFIX & top tether are available as standard for all variants. After the launch at the home soil, this car is expected to be available in other ASEAN countries such as Thailand, Indonesia, Brunei and Singapore.

ADULT OCCUPANT PROTECTION

AOP POINTS 14.07

MODIFIER Footwell rupture

	SAFETY ITEMS	TESTED VARIANT	OTHER VARIANT
AIRBAGS	Driver (DAB) : Front Passenger (PAB)	S : S	S : S
	SBR	S : S	S : S
SEATBELT	Double Pre-tensioner & Load Limiter for Driver	S	S
	Double Pre-tensioner & Load Limiter for Front Passenger	S	S
3-POINT BELT	All Forward Facing Seats	S	S
ABS	Anti-lock Braking System	S	S
ESC	Stability Control	S	S

Key:
 S : Standard on all variants
 O : Optional on base; Standard on higher variants
 V : Not available on base; Standard/Optional on higher variants
 X : Not available

PROTON IRIZ

ASEAN NCAP Q3 2014 (September)



COP Compliance 82%

CRS TYPE	P3	P1.5
ATTACHMENT	ISOFIX + Top Tether	ISOFIX
BRAND	Britax Duo Plus	Britax Baby Safe Plus SHR II Britax Baby Safe ISOFIX Base

CHILD OCCUPANT PROTECTION				
Dynamic Test (max. 24)	CRS Based Assessment (max. 12)	Vehicle Based Assessment (max. 13)	TOTAL (max. 49)	Compliance (%)
21.06	12	7	40.06	82

PROTON IRIZ WITH 2 AIRBAGS

SGR: GR SB | SDC: YES

ADULT OCCUPANT PROTECTION
 14.07 / 16.00

CHILD OCCUPANT PROTECTION
 82%

SIDE IMPACT TEST (UN R95) : PAB S

CRASH TEST SEPTEMBER 2014



From September 2013, ASEAN NCAP has introduced side impact test (UN R95) as a new pre-requisite for 4-Star and above. Also, Child Occupant Protection (COP) is presented in star-rating form.

Visit www.aseanncap.org for more info. Crash test video is available at ASEAN NCAP Youtube Channel.

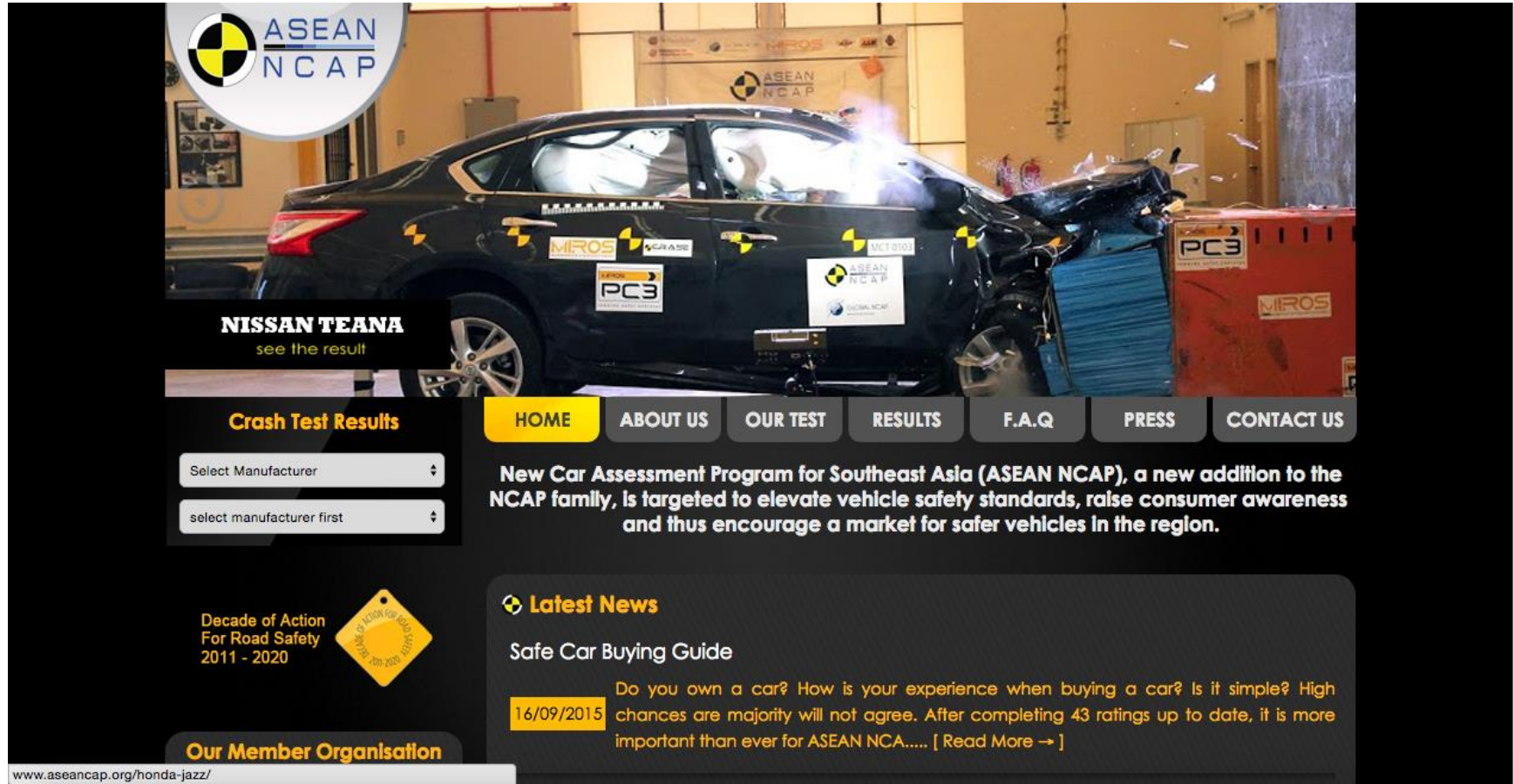

ASEAN NCAP

NISSAN TEANA
see the result

Crash Test Results

Select Manufacturer ▾
select manufacturer first ▾

Decade of Action For Road Safety 2011 - 2020

Our Member Organisation

www.aseancap.org/honda-jazz/

HOME ABOUT US OUR TEST RESULTS F.A.Q PRESS CONTACT US

New Car Assessment Program for Southeast Asia (ASEAN NCAP), a new addition to the NCAP family, is targeted to elevate vehicle safety standards, raise consumer awareness and thus encourage a market for safer vehicles in the region.

Latest News

Safe Car Buying Guide

16/09/2015 Do you own a car? How is your experience when buying a car? Is it simple? High chances are majority will not agree. After completing 43 ratings up to date, it is more important than ever for ASEAN NCA..... [Read More →]



Official & Supports ASEAN NCAP (casual posts)



The screenshot shows the ASEAN NCAP Facebook page. The page header includes the name 'ASEAN NCAP' and navigation options like 'Page', 'Messages', 'Notifications', 'Insights', and 'Publishing Tools'. The main content area features a large graphic with a hand icon and the text '#STOP THE CRASH PARTNERSHIP' and 'STOP THE CRASH PARTNERSHIP'. Below this, it identifies 'ASEAN NCAP' as a 'Non-Profit Organization' and provides options to 'Add Action Button', 'Like', or 'Message'. The right sidebar displays statistics for 'THIS WEEK': 658 Post Reach, 29 Post Engagement, 1 Website Click, and 0 of 0 Response Rate. A list of recent posts is visible on the right, including names like Zulhaidi Jawi, Aleda Mustafa, and Amirah Abdul Razak. The bottom of the page shows a search bar, a status update field, and a timeline of posts. The Windows taskbar at the bottom indicates the date is Thursday, 7 April, 2016, at 4:00 PM.

Social Media: Youtube

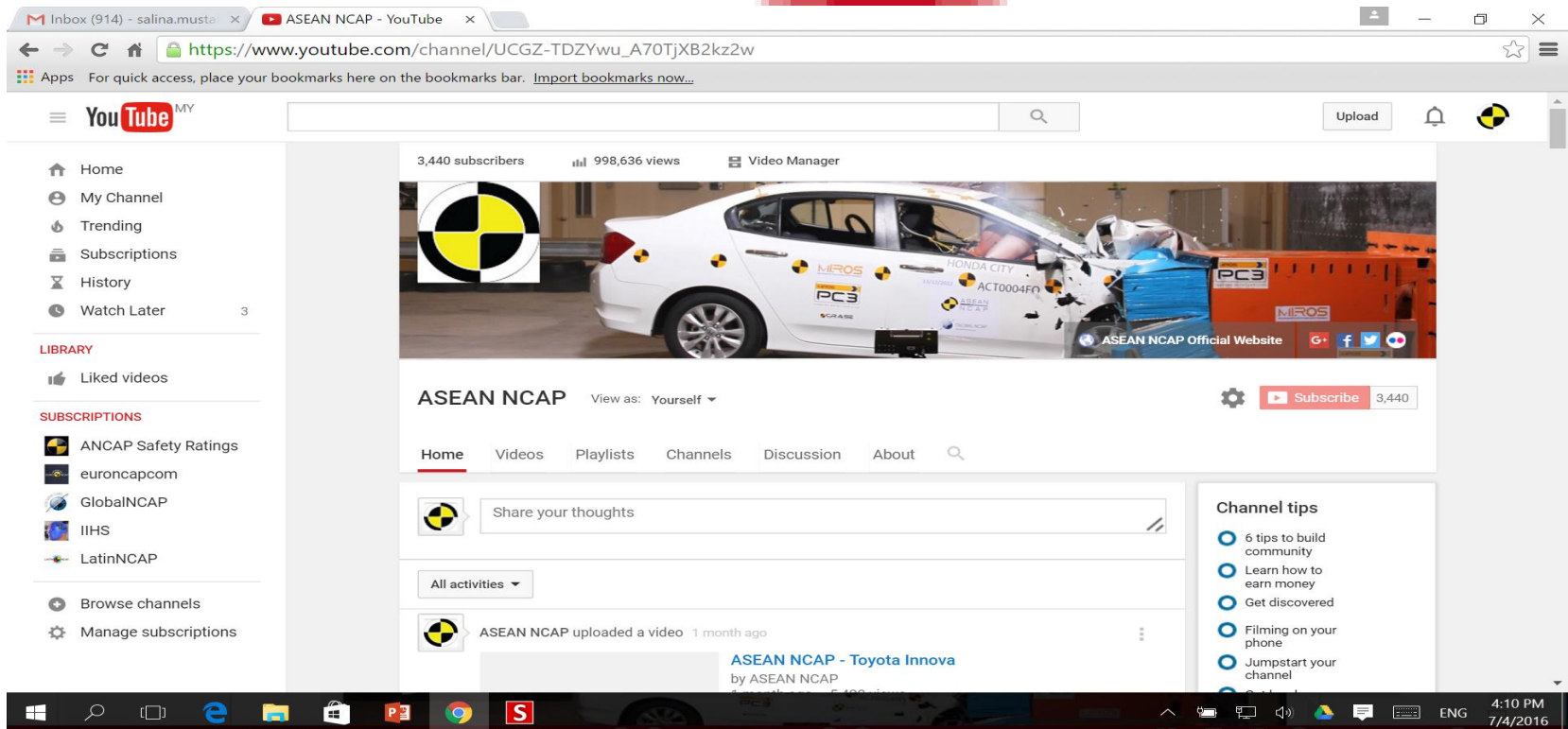

The screenshot shows a web browser window displaying the ASEAN NCAP YouTube channel. The browser's address bar shows the URL: https://www.youtube.com/channel/UCGZ-TDZYwu_A70TjXB2kz2w. The YouTube channel page features a banner image of a white car undergoing a crash test, with various labels like 'MIROS', 'PC3', and 'ACT0004FQ'. The channel statistics show 3,440 subscribers and 998,636 views. The left sidebar includes navigation options like Home, My Channel, Trending, Subscriptions, History, and Watch Later. Below the navigation is a 'LIBRARY' section with 'Liked videos' and a 'SUBSCRIPTIONS' list including ANCAP Safety Ratings, euroncapcom, GlobalNCAP, IIHS, and LatinNCAP. The main content area shows a video upload from 1 month ago titled 'ASEAN NCAP - Toyota Innova'. The right sidebar contains 'Channel tips' such as '6 tips to build community', 'Learn how to earn money', 'Get discovered', 'Filming on your phone', and 'Jumpstart your channel'. The Windows taskbar at the bottom shows the time as 4:10 PM on 7/4/2016.

General inquiries: aseanncap@gmail.com

Social Media: Twitter



@aseancap

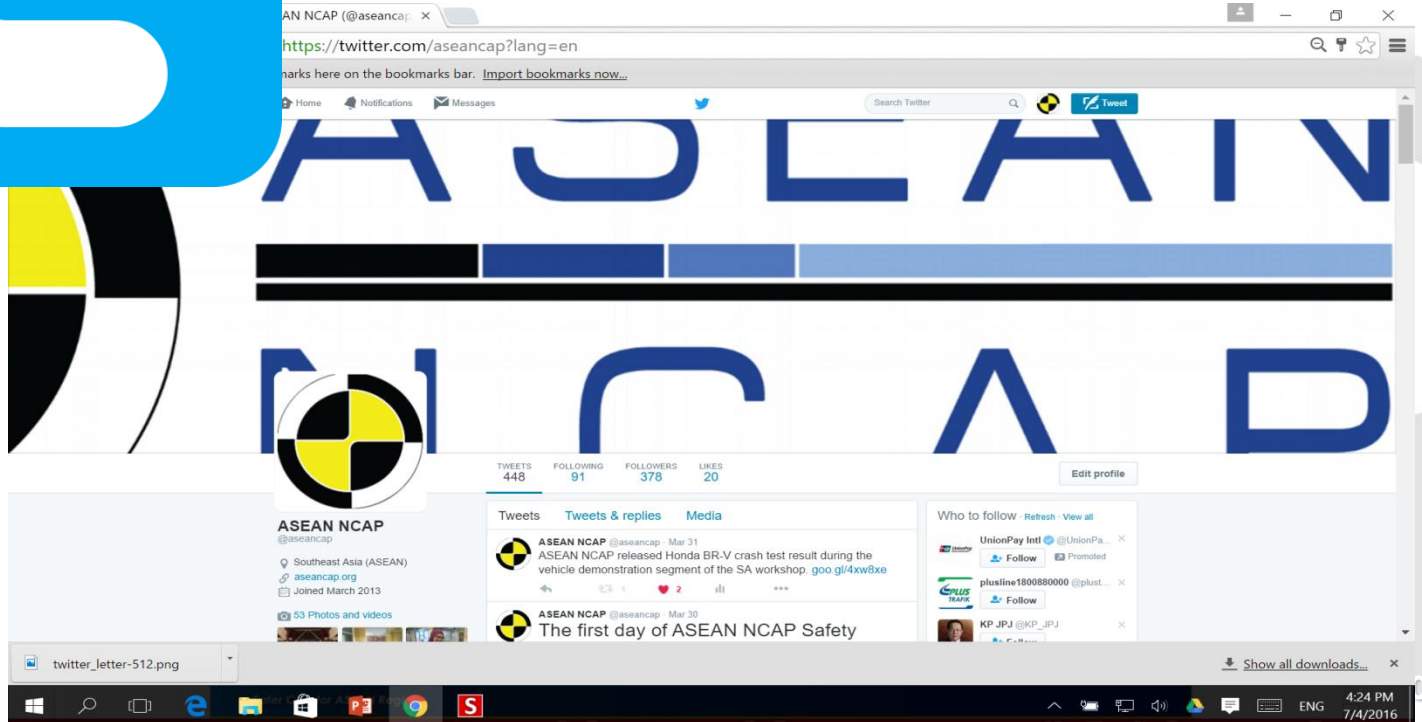



<https://flickr.com/photos/aseancap/>

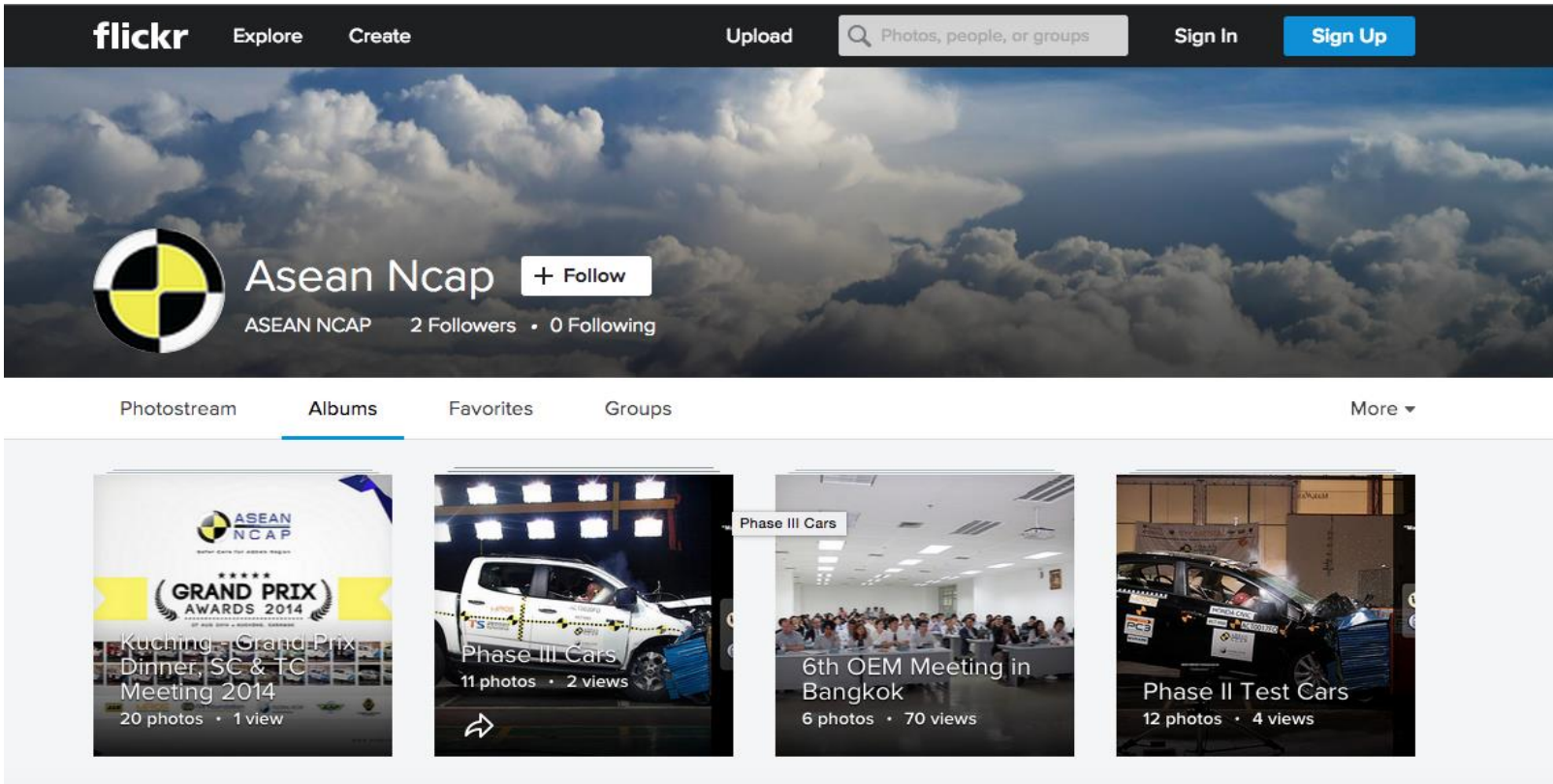

The screenshot shows the ASEAN NCAP profile on Flickr. The header includes the Flickr logo, navigation links for 'Explore' and 'Create', and buttons for 'Upload', 'Sign In', and 'Sign Up'. A search bar is also present. The profile banner features the ASEAN NCAP logo and the text 'Asean Ncap' with a '+ Follow' button, and 'ASEAN NCAP 2 Followers • 0 Following'. Below the banner are tabs for 'Photostream', 'Albums', 'Favorites', 'Groups', and 'More'. The main content area displays four photo albums:

- Kuching Grand Prix Dinner, SC & TC Meeting 2014**: 20 photos • 1 view
- Phase III Cars**: 11 photos • 2 views
- 6th OEM Meeting in Bangkok**: 6 photos • 70 views
- Phase II Test Cars**: 12 photos • 4 views

Activities by ASEAN NCAP

- ASEAN Automobile Safety Forum (AASF)
 - 001/2014: Kuching, Malaysia
 - 002/2014: Bangkok, Thailand (with TGGGS)
 - 003/2015: Bandung, Indonesia (with ITB)
- ASEAN NCAP Grand Prix 2014 in Kuching
 - To commemorate high achievers in crash test and automobile safety supporters
- ASEAN NCAP Road Tour 2015
 - To promote NCAP to the general public
 - To promote safety level in vehicles to road users

- To establish networking with vehicle manufacturers and stakeholders
- To commemorate high achievers in crash test and automobile safety supporters



- To engage and establish networking with Thai media and Royal Automobile Association of Thailand.
- To strengthen the collaboration between MIROS/ASEAN NCAP and TGGGS.





- To engage and establish networking with Indonesian media for future ASEAN NCAP promotional activities.
- The strengthen the existing collaboration between MIROS/ASEAN NCAP and ITB.



- To engage with related stakeholders and acquire valuable feedback towards the development of ASEAN NCAP protocol for Safety Assist (2017-2020).
- To provide training to related stakeholders on Fitment Rating System.





Question & Answer





General inquiries: enquiries@aseancap.org

Communication matters: salina@miros.gov.my